

Thermal Modeling of Power Devices in a Surface Mount Configuration

Introduction

This Application Note demonstrates how to develop a thermal model for power ICs. It then explains how the modeling of power ICs can be used to calculate the maximum power delivery possible during normal operation.

The Basic Model

Shown in Figure 1 is the cross-section of a power IC with the heat generating sources identified in red. The heat passes through the silicon substrate, a copper heat slug, and then into the foil layer on top of the printed circuit board. The heat transfers through the copper-plated vias which pass through the board transversely. The heat finally exits the assembly through the copper foil layer on the bottom of the printed circuit board. The first step is to define the heat source and represent the various paths by thermal resistance values and then calculate the power losses inside the power stage. The power loss over a time interval of Δt represents the amount of heat power fed into the system.

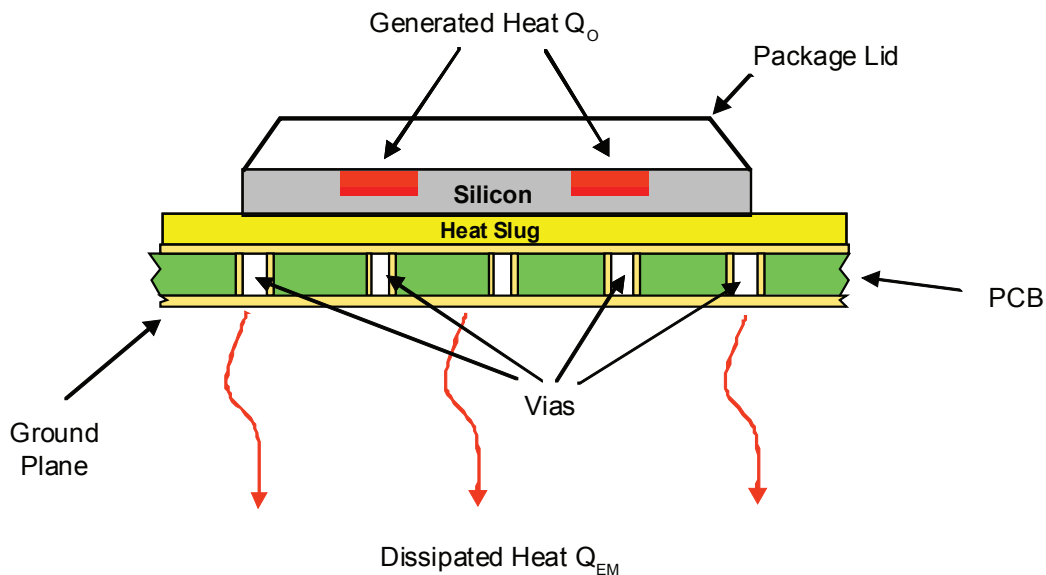

Figure 1: A Cross-sectional view of an IC thermal system

The copper foil directly beneath the heat slug serves as the thermal junction between the heat slug and the PCB. The PCB laminate itself is essentially a thermal isolator because of its high thermal resistance; therefore several vias are used to improve the heat transfer through the PCB. The bottom of the PCB features a large copper area (ground plane) because of its excellent thermal conductivity and the ability to optimize the heat dissipation into the air. This assembly can be depicted by the simple equivalent circuit shown in Figure 2. The Ohm's Law of heat transfer is similar to the Ohm's law for an electric circuit. Therefore we use familiar electrical symbols to describe the relations, as depicted in Figure 2.

Defining the Heat Source

The heat generated and depicted as Q_o in Figure 1 is attributed to three sources:

- Heat due to the current flow in the active devices of the logic circuit
- Heat generated as the result of switching losses
- Heat caused by the ON-resistance of each of the power FETs

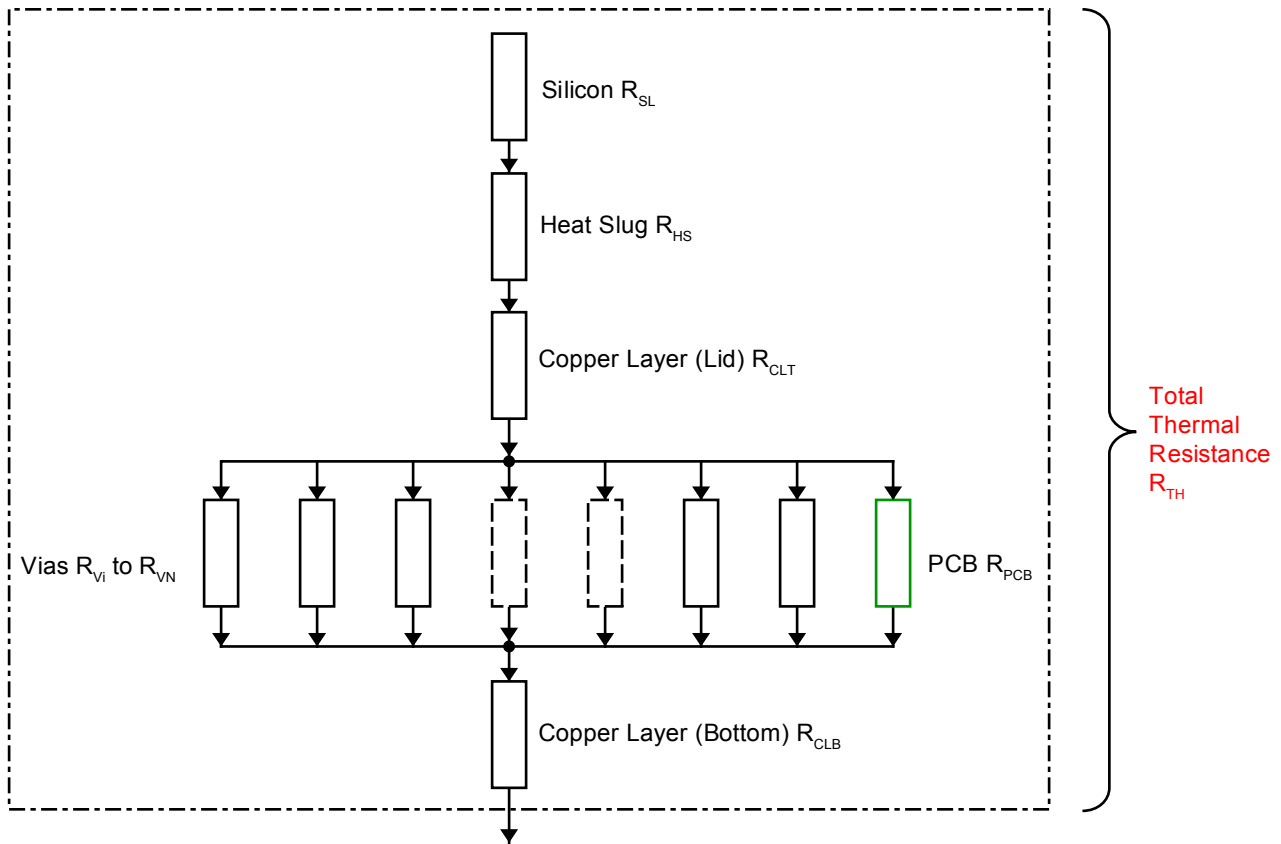

Figure 2: Equivalent thermal circuit for the power IC – circuit board configuration

The heat – expressed as power – developed in the logic circuit is more or less stable at 0.025 W. This is less than one hundredth of the power caused by the power FETs and therefore can be neglected in our analysis. The switching losses depend on the switching frequency, duty cycle and the supply voltage and will not be discussed in the following examples. However, in some applications it may be necessary to account for these losses in the heat source model.

The third source of heat is the most significant: The power FETs exhibit an ON resistance ($R_{DS(ON)}$) when turned on. Therefore a voltage drop occurs across the FETs, caused by the current flowing through them. The amount of heat expressed as power dissipated by this process can be expressed by the familiar relationship:

$$P_L = V_D \times I_C \tag{1}$$

Where:

- P_L = power loss
- V_D = voltage drop across the power FETs
- I_C = continuous current

In normal block commutation, two of the FET switches – one high-side FET and one low-side FET – are ON during each commutation step in the rotation sequence. To calculate the voltage drop, use the sum of the two ON-resistances – the one high-side and one low-side FET:

$$V_D = (R_{DS(ON)High Side} + R_{DS(ON)Low Side}) \times I_C \tag{2}$$

Where:

- V_D = voltage drop across the two ON power FETs
- R_{DS} = ON-resistance of a single ON power FET
- I_C = continuous current

When these two terms are combined, it is possible to calculate the complete power loss:

$$P_L = (I_C)^2 (R_{DS(ON)High Side} + R_{DS(ON)Low Side})$$

$$P_L = (I_C)^2 R_{DS(ON)} \quad (3)$$

The values for the ON-resistance can be found in the product data sheets of the SA306-IHZ and SA57-IHZ. The typical data given for the high-side (300 milliohms) and low-side (250 milliohms) power FETs is used for the calculation. To be able to use this equation for the definition of the heat source, power must be transformed into energy. The energy is defined by:

$$\Delta Q_0 = P_L \times \Delta t \quad (4)$$

Where:

ΔQ_0 = dissipated energy

P_L = power losses

Δt = time interval

The equivalent term for the thermal energy of the heat source is:

$$\Delta Q_{th} = \Phi_{th} \times \Delta t \quad (5)$$

Where:

$\Delta \Phi_{th}$ = heat energy

Φ_{th} = heat current

Δt = time

With the definition given for the heat current $\Phi_{th} = \Delta T/R_{th}$ we obtain:

$$\Delta Q_{th} = \frac{\Delta T}{R_{th}} \cdot \Delta t \quad (6)$$

Where:

ΔQ_{th} = heat energy

ΔT = temperature gradient

R_{th} = total thermal resistance

Δt = time

The last thing to do is to set these two increments of energy equal so that the dissipated electric energy becomes the input to the thermal system:

$$\Delta Q_0 = \Delta Q_{th}$$

$$P_L \cdot \Delta t = \frac{\Delta T}{R_{th}} \cdot \Delta t$$

$$I_C^2 \cdot R_{DS(ON)} = \frac{\Delta T}{R_{th}}$$

$$\Delta T = (R_{DS(ON)} \cdot R_{th}) \cdot I_C^2 \quad (7)$$

Taking a closer look at equation (7), there is a term for the temperature gradient ΔT as a function of the continuous current flowing through the power FETs. Both terms in the brackets are constant because neither the electric ($R_{DS(ON)}$) nor the thermal resistance (R_{th}) of the FET changes during operation. Also note that the temperature gradient will increase as the square of the continuous current. Equation (7) can be used to calculate the temperature gradient between the junction and ground-plane temperature that will be caused by a specific continuous current, or conversely as the maximum continuous current as a function of a specific temperature difference.

Calculating Total Thermal Resistance

Before using equation (7), the total thermal resistance of the system layers needs to be calculated. The thermal resistance depends on the layers and materials used. The thermal resistance of a solid state body is defined as:

$$R_{th} = \frac{s}{\lambda A} = \rho_{th} \frac{s}{A} \quad (8)$$

Where:

- R_{th} = total thermal resistance
- s = length of the thermal path
- λ = thermal conductivity of the material
- ρ_{th} = thermal density of the material
- A = cross-section of the object

For further calculations, the middle term will be used containing the thermal conductivity λ to calculate the thermal resistance. According to the Ohm's law of heat transfer theory the complete equation for the model shown in Figure 1 is:

$$R_{th} = R_{SL} + R_{HS} + R_{CLT} + \left(\frac{1}{R_{PCB}} + \sum_{i=1}^n \frac{1}{R_{Vi}} \right)^{-1} + R_{CLB} \quad (9)$$

Where:

- R_{th} = total thermal resistance
- R_{SL} = resistance from the FETs into the silicon
- R_{HS} = resistance from silicon into the heat slug
- R_{CLT} = resistance from the heat slug into the top layer of the PCB
- R_{Vi} = resistance from the top layer of the PCB into a single via
- R_{PCB} = resistance from the top layer of the PCB into the PCB
- R_{CLB} = resistance from the PCB via into the bottom layer of the PCB

Shown in Table 1 are the parameters used for the calculation of the total resistance:

Table 1. Parameters for the Calculation of the Total Thermal Resistance

Component	Length (x10 ⁻³ meter)	Cross-Section A(x 10 ⁻⁶ m ²)	Thermal Conductivity λ (W/mK)
Silicon	0.38	15.8/23.7	148
Heat Slug	1	100	220
Top Layer	0.035	100	384
PCB	1.5	100	0.26
Via	1.5	6.28x10 ⁻⁸	384
Bottom Layer	0.035	2160	384

Shown in Table 2 are the results for the thermal resistance of each component in the heat flow path. Note that in Table 2, the value for the thermal resistance for the SA57-IHZ and the SA306-IHZ differ.

Table 2. Total Thermal Resistance

Component	Thermal Resistance R_{th} (K/W)	
	SA57-IHZ	SA306-IHZ
Silicon	0.405	2.264
Heat Slug	0.045	
Top Layer	0.912 x 10 ⁻³	
PCB + Vias	2.479	
Bottom Layer	0.140 x 10 ⁻³	
Total	2.913 K/W	2.789 K/W

Why Heat Spread Depends on the Number of Active FETS

When a brushed DC motor is driven, only a single pair of FETs is in use continuously. In this case the area for heat transfer into the silicon is simply twice the area of a single FET structure. However, in the case of a 3-Phase BLDC motor application, the pairs of FETs change in accordance with the electric angle of the rotor. This means that all six FETs become active in an alternating sequence. Although only two FETs are active at any instant, the heat is spread over three times the area. However, in practical tests it has been determined that the effective heat transfer has the value of the single half-bridge operation divided by $\sqrt{2}$.

Active and Passive Heat Dissipation

A model is now in place that transfers the heat from the power FETs through several layers into a ground plane on the backside of the PCB. An additional step is required to calculate the heat that dissipates into the ambient air. This heat transfer from a solid state body into air is defined by:

$$\Delta Q_{EM} = \alpha \cdot A \cdot \Delta T \cdot \Delta t \quad (10)$$

Where:

ΔQ_{EM} = dissipated heat energy

α = heat transfer coefficient

A = heat dissipating area

ΔT = temperature gradient between air and dissipating ground plane area

Δt = time

To calculate the results for a static operation, it makes sense to eliminate time. The equation for the heat energy can be easily transformed into an equation for heat power by eliminating the time factor:

$$P_H = \alpha \cdot A \cdot \Delta T \quad (11)$$

The value for the heat power is given by equation (11). The thermal current multiplied by the input power (= electric power losses) gives the amount of power in watts that has to be dissipated into air.

Therefore:

$$\Delta T_1 = (R_{DS(ON)} \times R_{th}) \cdot I_C^2$$

with ΔT_1 = temperature gradient between the junction temperature and the temperature of the backside of the PCB and:

$$\Delta T_2 = \frac{1}{\alpha \cdot A} P_H$$

with ΔT_2 = temperature gradient between the temperature of the backside of the PCB and the ambient air.

The thermal system is in balance, when the dissipated heat power P_H is equal to the electrical power losses P_L :

$$P_H = P_L$$

$$\alpha \cdot A \cdot \Delta T_2 = R_{DS(ON)} \cdot I_C^2$$

$$\Delta T_2 = \frac{1}{\alpha \cdot A} \cdot R_{DS(ON)} \cdot I_C^2$$

$$\Delta T_1 - \Delta T_2 = \frac{1}{\alpha \cdot A} \cdot R_{DS(ON)} \cdot I_C^2$$

Where:

$$\Delta T_1 = (R_{DS(ON)} \times R_{th}) \times I_C^2$$

$$T_0 - T_1 = (R_{DS(ON)} \times R_{th}) \times I_C^2$$

These two equations can be combined into:

$$T_0 - T_2 = \left(\frac{1}{\alpha A} + R_{th} \right) \cdot R_{DS(ON)} \cdot I_C^2 \quad (12)$$

Where:

T_0 = SA306-IHZ or SA57-IHZ junction temperature

T_2 = ambient air temperature

With this equation it is possible to calculate the temperature offset as a function of a specific continuous current, and vice versa.

AN51

Calculating the Maximum Continuous Current

To calculate the maximum continuous current, transform equation (11) into:

$$I_c = \sqrt{(T_0 - T_2) \cdot \left[\left(\frac{1}{\alpha A} + R_{th} \right) \cdot R_{DS(ON)} \right]^{-1}} \quad (13)$$

The absolute maximum current can be calculated for a maximum continuous junction temperature T_0 of +135°C and a maximum ambient temperature T_2 of +85°C. At these operating conditions, a maximum temperature gradient can be set of 50K into equation (13).

When the temperature gradient is set, the value for the absolute maximum continuous current depends only on the heat-transfer coefficient α . The other parameters such as the size of the heatsink, the thermal resistance and the ON-resistance, are fixed by the system design. However, the heat transfer coefficient α is not a fixed constant and can vary according to the air movement. Commonly there are three main ranges for α defined for different flow speeds along a metal area:

Static (still air):	3.5 to 35 (inside a case)
Passive cooling:	23 to 70 (convection)
Active cooling:	58 to 290 (fan)

For valid dimensioning it makes sense to calculate the first-order approximation for a worst case scenario; therefore, the lower value should be used for each cooling alternative.

5. References

1. SA57 Pulse Width Modulation Amplifier Data Sheet, www.apexanalog.com
2. SA306 Pulse Width Modulation Amplifier Data Sheet, www.apexanalog.com
3. 3-Phase Switching Amplifier Application Note SA306, www.apexanalog.com
3. Optimizing Power Delivery in PWM Driver ICs, Application Note AN50, www.apexanalog.com

NEED TECHNICAL HELP? CONTACT APEX SUPPORT!

For all Apex Microtechnology product questions and inquiries, call toll free 800-546-2739 in North America.

For inquiries via email, please contact apex.support@apexanalog.com.

International customers can also request support by contacting their local Apex Microtechnology Sales Representative.

To find the one nearest to you, go to www.apexanalog.com

IMPORTANT NOTICE

Apex Microtechnology, Inc. has made every effort to insure the accuracy of the content contained in this document. However, the information is subject to change without notice and is provided "AS IS" without warranty of any kind (expressed or implied). Apex Microtechnology reserves the right to make changes without further notice to any specifications or products mentioned herein to improve reliability. This document is the property of Apex Microtechnology and by furnishing this information, Apex Microtechnology grants no license, expressed or implied under any patents, mask work rights, copyrights, trademarks, trade secrets or other intellectual property rights. Apex Microtechnology owns the copyrights associated with the information contained herein and gives consent for copies to be made of the information only for use within your organization with respect to Apex Microtechnology integrated circuits or other products of Apex Microtechnology. This consent does not extend to other copying such as copying for general distribution, advertising or promotional purposes, or for creating any work for resale.

APEX MICROTECHNOLOGY PRODUCTS ARE NOT DESIGNED, AUTHORIZED OR WARRANTED TO BE SUITABLE FOR USE IN PRODUCTS USED FOR LIFE SUPPORT, AUTOMOTIVE SAFETY, SECURITY DEVICES, OR OTHER CRITICAL APPLICATIONS. PRODUCTS IN SUCH APPLICATIONS ARE UNDERSTOOD TO BE FULLY AT THE CUSTOMER OR THE CUSTOMER'S RISK.

Apex Microtechnology, Apex and Apex Precision Power are trademarks of Apex Microtechnology, Inc. All other corporate names noted herein may be trademarks of their respective holders.